

EM-243-PLI DC-MOTOR CONTROLLER 12-48V 50A

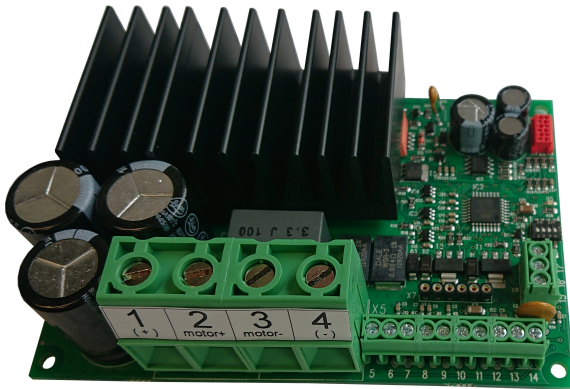

FEATURES

- 2ch pulse counter inputs
- pulse counter limits.
- for motor with pulse output
- overcurrent (torque) limit
- overvoltage brake
- recommended motor size max.
350W @ 12V
500W @ 24V
600W @ 48V
- speed setting
- PWM 2 or 16 kHz
- flexible control inputs
- brake output
- impulse / continuous mode
- rail base mountable
- prog. v2.0 two option added to param. 10
- prog. v2.1 pulse input freq. max. improved
- prog. v2.2 added learn routine to par. 23

APPLICATIONS

- hatch opener
- actuator stroke and speed adjust

EM-243-PLI is a full bridge DC-motor starter. It is designed to work with DC-motor in applications where some special functions are needed. Starter has adjustable acceleration and deceleration ramps, which make possible the smooth starts and stops. Adjustable current limit protects motor against overcurrent and it can also be used as an end-stop. This device has also two settable speeds, which are useful in positioning applications. Control inputs FW and BW start the forward and backward run. STOP is for the motor shut-down. In -PLI version there are also PULSE COUNTER which can be used for end limit use. This counter value keep in memory of card also when power is turned off. SPEED-2 input activates preset speed-2, but it can also be used as input for analog speed control signal 0-5V. FAULT output terminal indicates different failure situations. This pin is normally high, but is pulled down in overheat and conditionally also in current trip situation. DISABLE input disables driver as long as this is pulled down externally. Also it is possible to link fault and disable pins of several units together and achieve a synchronous stop. The BRAKE output can be used to release external magnetic brake or control brake resistor in overvoltage situation.

There are two selectable control modes, continuous and impulse. In continuous mode the motor runs as long as the control is active. In impulse mode a short command starts the motor, and only a new impulse will change the status. There is also few special settings start-kick and auto reverse. The card has selectable input logics. Inputs are divided in two groups, control and limit -inputs. Groups can be individually set for NPN or PNP logic. The parameters are set with EM-236 interface unit. Operation of the controller and some of its functional values can also be monitored with EM-236 interface unit.

TECNICAL DATA EM-243-PLI prog. v2.2 / PCB -C

Supply voltage nominal 12-48V, limits 10-58V
 Start up voltage 9V, shutdown voltage 8V
 Idle current typ 15mA
 Motor current max. with 2kHz pwm
 100% pwm 50A , 20-99pwm% 35A and peak 100A (5s)
 Motor current max. with 16kHz pwm
 100% pwm 40A , 20-99pwm% 20A and peak 60A (5s)
 Current limit adjustable 1-100A
 NOTICE ! during start ramp the current limit is 50% boosted
 Overheat limit 100°C
 Start and stop ramp adjustable 0-5s
 PWM frequency 2kHz or 16kHz
 I-limit input scale (stop) 0-4V = 0-100A
 Input control logic: high =4-30V, low=0-1V
 Pulse input imped. typ 10kohm
 Pulse input freq max. 1000Hz
 Control input impedances typ. 10kohm
 Control input response time typ 5ms.
 Fault out. NPN open coll. max. 40V / 1A
 Fault in activates Uin < 1V (NPN)
 Fan-output switch on 55°C, off 50°C (only pcb Cv.2 of later)
 Fan-output NPN max. 40V 2A
 Break load output Max. 60V 5A
 Vout lim output max 25V 15mA
 Motor and supply connectors 2.5mm
 Control connectors 1mm
 Dimensions 107x73x40mm
 Dimensions in DIN-rail base 110x80x55mm
 CE-tested for industrial environment (EMC)
 Operating ambient temp (Ta) -40...60°C
 Weight 190g

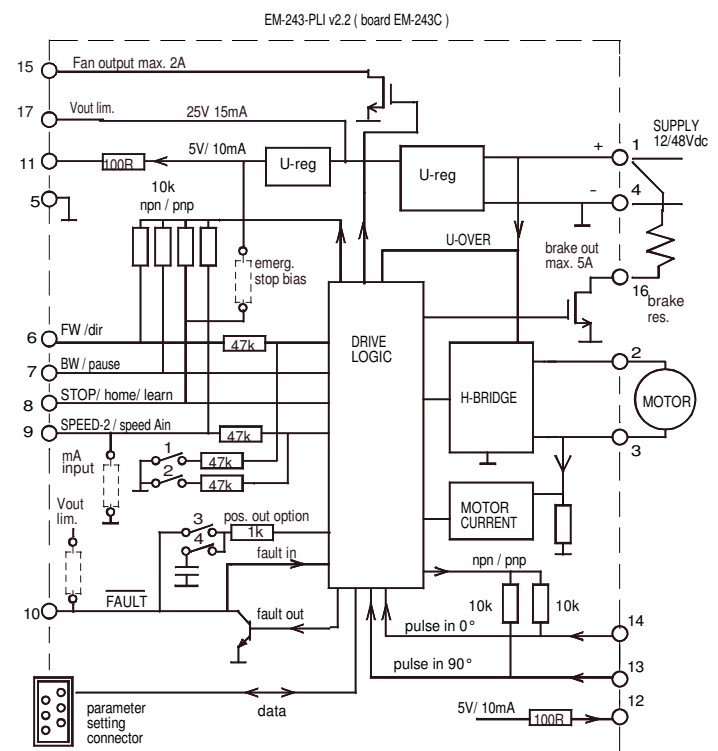

CONNECTIONS

Supply voltage must be filtered DC of 10-58V, and ripple should be less than 30% at full load.
CAUTION ! Wrong polarity can damage the unit.
CAUTION ! Unit doesn't have an internal fuse, so an external fuse should be added if fuse required.

HOME RUN = PULSE COUNTER RESET
 LEARN = RANGE LEARNING AND COUNTER RESET

Pulse counter have to reset to calibrate position. Calibration can be done by start HOME RUN. Then driver start to run BW direction at speed-2. In this running mode limits are not active, so motor run as long as HOME RUN is active. When HOME RUN stops the counter will reset also.
 HOME RUN can be started with different way: long push same time with FW and BW commands or with STOP / HOME / LEARN command or with BW commands. See parameter 23.
 LEARN routine makes HOME RUN and also determinates range. Routine make first HOME RUN and after that runs end to end and stores the range. LEARN can be selected with set par 23=5

ADJUSTMENT AND SETTINGS (prog ver. EM-243-PLI v2.2)

Adjusting and parameter setting of eg. current limit value, ramp times and speed-2 value is done with the EM-236 interface unit. With EM-236 the parameters and adjusted values can also be copied to multiple devices accurately and reliably.

SETTABLE PARAMETERS 27pcs. (defaults in brackets)

- 1- command mode: 0,1 and 2 (0)
 0= continuous FW / REV
 1= impulse commands FW / REV. with stop
 2=impulse commands FW / REV without stop
- 2- start condition combinations: 0-3 (1)
 0= start both direction after I-trip and Stop
 1= start only opposite direction after I-trip
 2= start only opposite direction after Stop
 3= start only opposite direction after I- and Stop
- 3- input logic combinations 0-3 PNP/NPN (0)
 0= command and pulse inputs as PNP (positive)
 1= command inputs NPN, and pulse inputs PNP
 2= command inputs PNP. and pulse input NPN
 3= command and pulse inputs NPN (negative)
- 4- running speed-1: 0-100% / 0-100 (100)
 0= speed-1 set with analog signal to pin-9 (0-5V)
- 5- running speed-2: 0-100% / 0-100 (50)

- 6- current limit FW: 1-100A / 1-100 (10)
- 7- current limit REV: 1-100A / 1-100 (10)
- 8- Trip combinations: 0-3 (1)
 0= no I-trip, no zero-current-trip
 1= only I-trip
 2= only zero-current-trip
 3= both I-trip and zero-current-trip
- 9- I-trip delay: 0-255ms / 0-255 (20)
- 10- Fault output combinations: 0-5 (1)
 0= I-trip and zero current won't cause fault output signal
 1= only I-trip causes fault output signal
 2= only zero current causes fault output signal
 3= both I-trip and zero current causes fault output signal.
 4= overcurrent indication = activates when overcurrent
 5= "run" indication = activates when motor run
- 11- overvoltage limit: 15-60V / 15-60 (35)
 Overvoltage can be caused by load driving the motor or when braking the speed down but supply can not accept the current back from driver. Exceeding the limit will cause the power stage set to free-wheel state.
 With a direct battery supply the brake current is charging the battery and the voltage will not normally rise.
 There is also 40V fixed dynamic brake point = motor pole shorted
- 12- load compensation: 0-255 / 0-255 (0)
 Load compensation (Rxl) improves low speed and start torque, but too high compensation achieve unstable running.
 Run motor at low speed (30%) Increase compensation with small steps until motor start behaviour unstable, then decrease value about 10%
- 13- timeout: 0-255s. / 0-255 (0=not in use) (0)
- 14- Reset for start and hour-counter 0/1 (0)
 selecting 1 and push SAVE => reset counters
- 15- start ramp: 0.5s / 0.500 (100)
- 16- stop ramp: 0.5s / 0.500 (100)
- 17- start-kick 0-200ms / 0-200 (0)
 This gives full drive at start and I-lim is 30A
 The start kick length is 0-200ms.
- 18- I-trip auto reversing 0.5s / 0.500 (0)
 Change automatically run direction when I-trip occurs the reversing time will select with this parameter
- 19 BW counter limit 0-65000 count / 0-65000 (10)
 Value 0 = limit is disabled
- 20 FW counter limit 0-65000 count / 0-65000 (1000)
 Value 0 = limit is disabled
- 21 BW-limit advance 0-50000count / 0-50000 (100)
- 22 FW-limit advance 0-50000count / 0-50000 (100)
- 23 HOME RUN start cond. (=pulse counter reset) 0-4 (0)
 0 = simultaneous FW & BW command 5sec. push
 1 = also stop input long push 5s. starts HOME RUN
 2 = also new 5s. BW command starts HOME RUN if motor has stopped on limit or if I-trip occurs.
 3 = HOME RUN only with 5sec. stop input
 4 = HOME RUN disabled
 5 = LEARN with 5s push with Learn input (pin 8) and HOME RUN with 5s. same time command with FW and BW
- 24 PWM-frequency 1=2kHz / 2=16kHz (1)
- 25- Pin-16 (brake load) options 0-1 (0)
 0= regen. braking = switch on when overvoltage exceed
 1= running indication = switch on pin-15 when motor run
- 26 Serial line configuration, speed, parity, and number of stop bits (1)
 1 =9600bps 8N1 5 =19200bps 8N1
 2 =9600bps 8N2 6 =19200bps 8N2
 3 =9600bps 8E1 7 =19200bps 8E1
 4 =9600bps 8O1 8 =19200bps 8O1
- 27 Modbus address 1-247 (1)

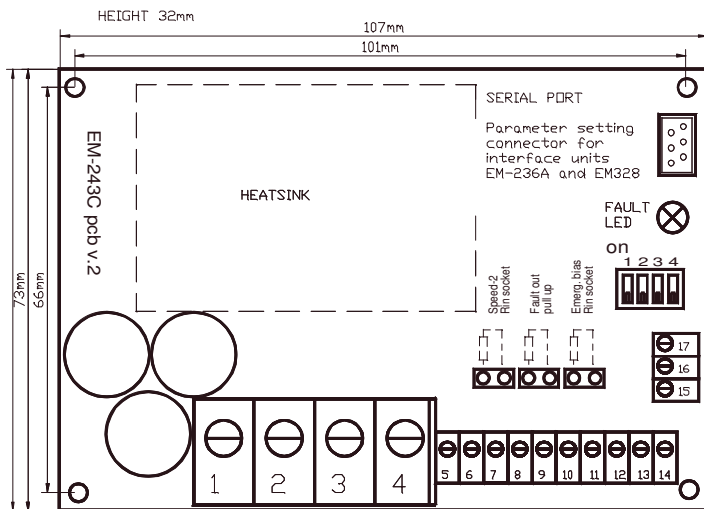

Vout 24V
 brake load out
 Fan output

FAULT-LED signal codes

- 1. power on one blink
- 2. current on limit led is lit
- 3. current trip fast blinking...
- 4. zero-cur trip long blink- short pause...
- 5. overvoltage 4 x blink -pause...
- 6. overheat short blink- long pause...
- 7. timeout 3 x blink + long blink...
- 8. fault input 2 x short + 1x long blink...

MONITORABLE VALUES

- 1/6 Motor current 0-100A (0-100)
- 2/6 PWM-level-% 0-100% (0-100)
- 3/6 hour counter (max.65535h)
- 4/6 start counter (max.65535)
- 5/6 carry counter for start counter
- 6/6 pulse counter value 0-65000

NOTICE.

Pulse counter should count down when motor run to BW direction or in HOME RUN. Counter value can be monitored with monitor value 6. IF NOT. then you have to interchange pulse input wires 13 <->14 or interchange motor wires 2<->3.

If pulses counter did not count. then check parameter 3 settings (pulse input PNP or NPN)

Max input pulse frequency is 1000Hz/pulse line
 For example: 3000rpm x 12pulses/round = 600Hz

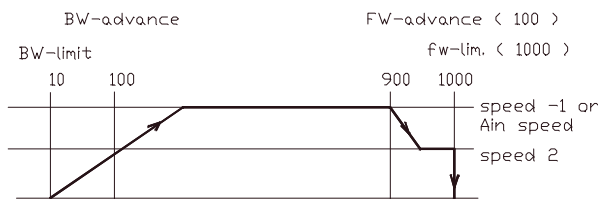
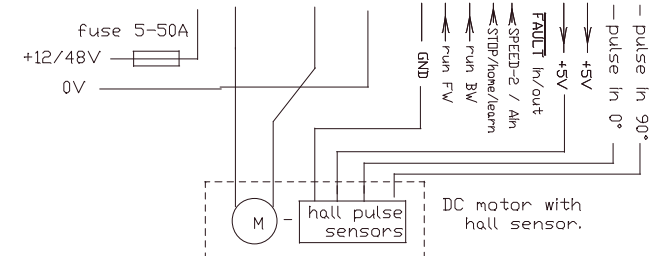

Example of function of limit. (with default values)
 In limit advance point changes speed to the speed-2
 In limit point the driver brakes motor to stop