

EM-282D basic applications (pcb -Dv3 firmware 282D v 2.1)

282dapp 18042922 KMK

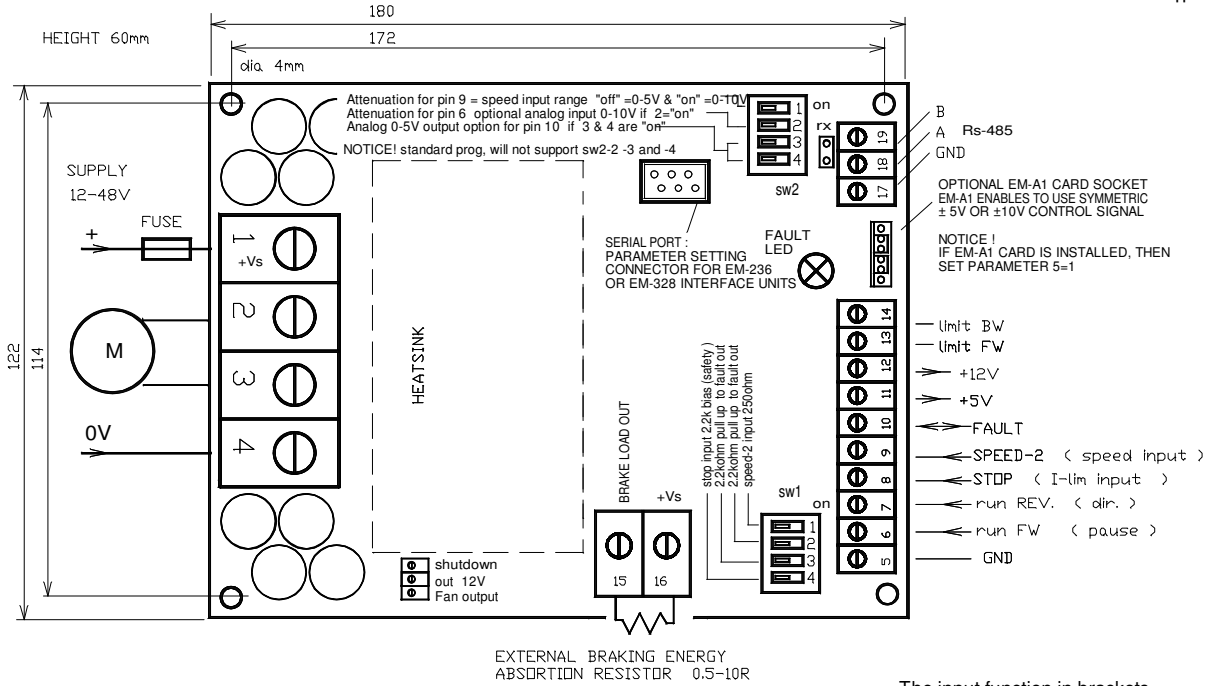

Optional braking resistor.
Braking resistor needed in application where motor can supply energy back to supply
Recom. values 0.5R @ 12V, 1R @ 24V
Resistor power rating 50-200W, depends on solution

The input function in brackets is activated with parameter setting.
- speed input (param 5=0)
- speed input +dir. (param 5= 1)
- I-lim input (param 6&7= 0)

2-speed mode

Start commands with digital fw/bw switch.
Stop impulse from switch will stop the motor.
Active stop command will not prevent the new start with fw or bw command.

"speed-2" activates slow speed, value set with parameter 5. Notice! When speed-2 is activated the stop impulse will stop motor immediately (no ramp).
Command mode to continuous or impulse is set with parameter 1. Input logic default is PNP but can be changed to NPN with parameter 3.
In PNP mode the control command can be 5-30Vdc
In NPN mode switches can connect to gnd (0V)

Analog speed control mode-1

This mode is selected by setting param.5 = 0
Speed-2 input is changed in to speed input.
Motor starts with digital command fw or bw.
The speed adjust signal can be 0-5V or 0-10V voltage signal. The basic range is selected with dip-switch 1. and the fine tuning of range can be done with parameter 4
In analog control mode-1 pls. use a PNP logic for control logic. (see param. 3)
Potentiometer recom. value 1-100kohm

Analog speed control mode-2

This mode is selected by setting par.5 to val.1
Speed-2 input will be changed to speed input and rev. input will work as direction change input. (open =fw. / closed =bw.)
Motor starts when speed control signal starts to increase from 0V. The basic range is selected with dip-switch 1. and the fine tuning of range can be done with parameter 4.
Use PNP logic for control logic (see param. 3)
Potentiometer recom. value 1-100k

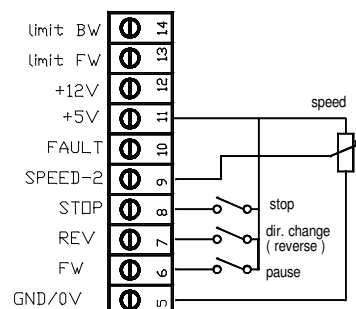
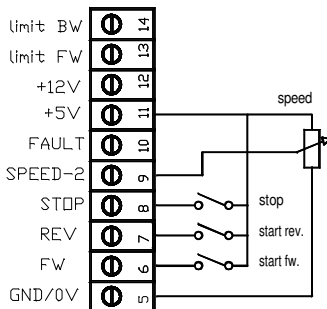
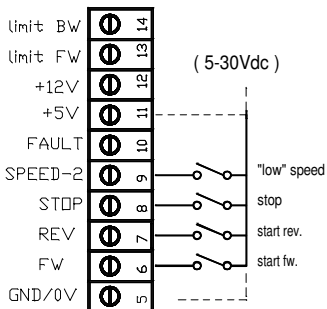

Analog torque (current) adjust

Set parameters 6 & 7 to val. 0, then stop input is changed to work as torque adjust input.
This option can be used with all above examples. The adjust signal range is 0-5V.
Recom. potentiometer value 1-100k

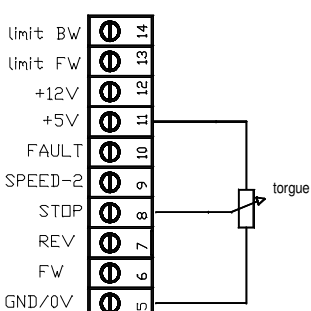

Fault output/input pin.

This pin works as NPN output in case of overheat and other cases which are defined with parameter 10.
This pin works also as disable input if it is externally pulled down. When this pin is pulled down the driver stops immediately and will not start with any command !
This input can be connected as shown below or only to LED or switch. The led voltage can be internal 5V or 12V or external 5-30V.

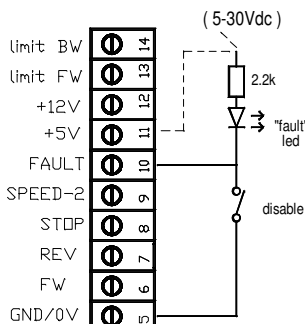

Limit inputs

These inputs stop and disable run to fw. or bw. direction. As long as limit input is active the drive is disabled to this direction.
Normally the limit inputs stops motor quickly with dynamic brake but in 2-speed mode dynamic brake is enabled only when speed-2 is activated
The logic of limit inputs can be set with param. 3
In PNP mode the control voltage can be 5-30Vdc
In NPN mode switch can be connected to gnd (0V)

