

# EM-316A BRUSHLESS DC-MOTOR DRIVER 12-35V 10A

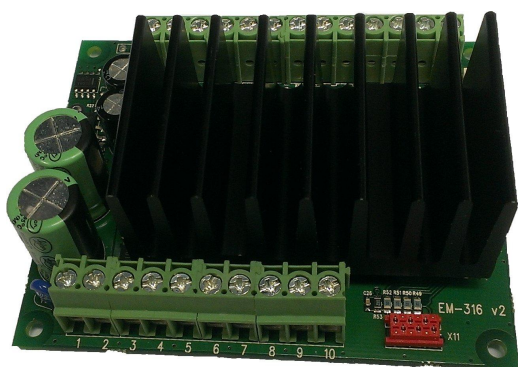

## FEATURES

- Three phase output
- Speed and torque adjustment
- Open/closed loop modes
- Dynamic braking
- Current limit and trip
- Fault and overcurrent outputs
- 60° / 120° commutation options
- Good efficiency
- Low EMC emissions
- DIN-rail mountable
- EM-316A is compatible with EM-316
- Added EM-A1 card slot for  $\pm 10V$  control
- Rpm-pulse output option ( prog v1.5 )

## GENERAL

EM-316A is brushless DC-motor driver with hall sensor feedback. The unit has a mosfet power stage with good efficiency and it meets also today's EMC requirements. The driver can be used with 120° or 60° commutation. The unit has the basic digital command inputs like direction, brake, start/stop, disable and there is analog inputs for speed and current control. One digitally presettable second speed (speed-2) is possible to activate with digital command input. EM-316 has two NPN outputs for fault and overcurrent indication use. Some input and output functions can be modified with parameters. Driver includes overvoltage, undervoltage and overtemperature protections. These fault situations are indicated with fault on-board LED. Overtemperature and current limit situations can be reset with reset input, reset-timer or by setting analog speed control to value to 0.

There are two control options for speed. Direct control ( open loop ) sets motor voltage in proportion to control voltage as with a standard DC-motor. Closed loop uses hall sensor feedback for speed control, this mode offers good speed regulation. Start and stop ramps work in both mode. Speed adjust range, closed loop rpm range and ramps can be set with parameter. Analog input are filtered so that there can also use PWM signal for control speed and current. EM-316A has added card slot for EM-A1 card, which make possible to use symmetric control -5..0..+5V ( rev-stop-fwd ) EM-A1 card generate also -5V auxiliary voltage for local potentiometer control

Setting can be done digitally with EM-236 interface unit or with Emen-Tool lite program installed in PC and EM-268 adapter cable. Parameters stored into nonvolatile memory of device. This interface unit can also be monitored the current and rpm of motor.

Device can be installed in DIN-rail base and some enclosure options are also available.

## TECHNICAL DATA

Supply voltage 12-24V ( 11-35Vdc )  
 Overvoltage shut down 40V  
 Idle current typ. 30mA  
 Max current 10A cont ( Tamb. 40 °C )  
 Max current peak 25A ( max 2s )  
 Pwm frequency typ. 16kHz  
 Overtemperature Temp shut down 90°C  
 Current limit setting 0.1-25A ( step 0.1 A )  
 Current limit analog scale 0-5V = 0-25A  
 Logic level of digital inputs  
 "off" = 0-1V or open / "on" = 4-30V  
 Input impedance of logic inputs 10k  
 Response time of digital input 2ms  
 Analog input range 0-5V up to 0-10V  
 Input impedance of analog inputs 100k  
 Input filter of analog input 100Hz  
 Overcur. and fault outputs NPN max 50mA  
 EMC measured for industrial and household env.  
 PCB material flammability class UL94V-0  
 Dimensions 89x73x32mm  
 Weight 200g

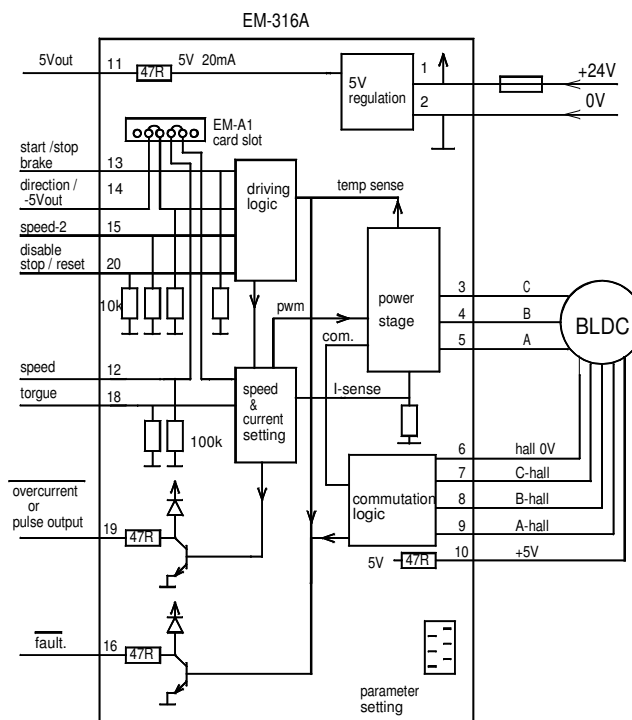

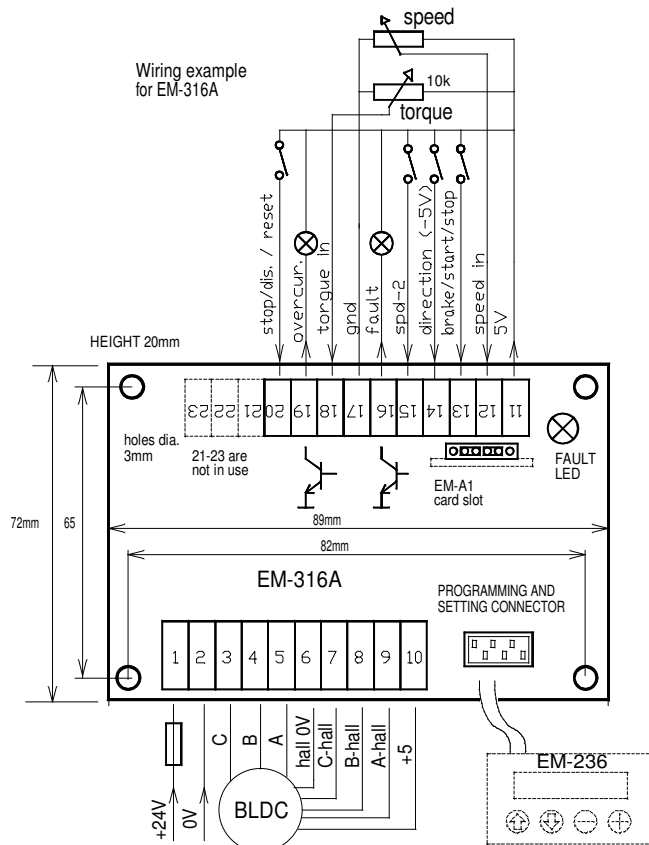

### SETTABLE PARAMETERS (prog. 316 v1.5)

EM-316A parameters set with interface unit EM-236 or with Ementool-Lite and EM-268

1. mode: open loop =0 / closed loop=1 ( 0 )
2. closed loop range 0-4 ( 3 )
  - 0=3000rpm
  - 1=15000rpm
  - 2=9000rpm
  - 3=5000rpm
  - 4=3000rpm
3. start ramp 0-5s / 0-50 ( 1 s )
4. stop ramp 0-5s / 0-50 ( 1 s )
5. I-trip delay 1-255ms / 0-255 0=no trip ( 200ms )
6. scale start speed 0-25.5% / 0-255 ( 0 )
7. scale gain 0-2.55 / 0-255 ( 200 )
8. closed loop dynamic P-factor 1-200 ( 10 )
9. closed loop dynamic I-factor 1-200 ( 10 )
10. commutation angle 120°=0 / 60°=1 ( 0 )
11. pin 13 input mode
  - 0 = brake
  - 1 = start / stop
  - 2 = start / brake
12. current limit 0-25A / 0.1-250 ( 4A )
  - 0 = current setting with pin 18
13. speed-2 value 0-100% / 0-100 ( 50 )
14. I-trip reset mode ( 0 )
  - 0 = only with disable pin
  - 1 = with speed input change 0 to up
  - 2 = with direction input
  - 10-200 = timer reset 1-20s. ( 0 )
15. Over temp reset mode ( 0 )
  - 0 = only with disable input
  - 1 = with speed input change 0 to up
  - 2 = 10-200 timer reset 1-20s.
16. I-trip indication ( 0 )
  - 0 = I-trip indication to pin16
  - 1 = No I trip indication to pin 16 or 19
  - 2 = I-trip indication to pin 19
  - 3 = pin 19 reserved only for I-trip indication
17. pulse output for pin19 0-5 ( 0 )
  - 0 = not in use = pin 19 set with parameter 16 )
  - 1 = 3pulse/round ( possible only when param 2 is 2,3 or 4 )
  - 2 = 1pulse/round
  - 3 = 1pulse/ 2round
  - 4 = 1pulse/ 3round
  - 5 = 1pulse/ 6round

### MONITOR VALUES

1. current 0-25A / 0-250
2. hall rpm 0-1000 / 0-1000Hz

### TAKE IN USE

Operating voltage 12-35Vdc ripple less than 20%  
An external supply fuse is recommended ( 2-16A )

Be sharp when connect motor wires, because there is lot of combination. If motor takes much current or run roughly then change wiring.

Default settings are in brackets in parameter list.  
This are good start-up values

In example picture beside there all input connected, but device work also with less wiring. So connect only needed functions.

Overcurrent and fault outputs are NPN type, and pull when activates, This could also connect to PNP input if uses 2.2k external pull up resistor

Speed adjusting input range can be set with parameter 6 and 7. see picture below

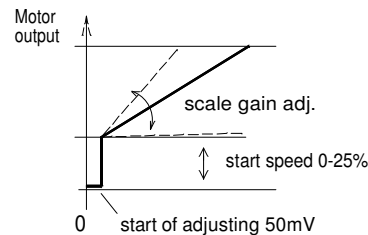

### CONTROL INPUTS

> speed input

Speed input is a analog control input for speed setting. Set signal can be between 0-5V and 0-10V  
Speed scaling can be made with parameter 6 and 7.  
EM-316A has optionally possibility to use symmetric control (  $\pm 5V$  up to  $\pm 10V$  ). This can be done with connecting the EM-A1 into card Remove two jumper and put A1 card into slot. Then the direction input will give -5V ( max. 5mA ), and speed input is symmetric, refered to gnd ( 0V =stop). If local potentiometer is used, then connect potentiometer ends to +5V ( pin 11) and -5V ( pin14) and the slide can connect to pin12 . Use potentiometer which nominal value is 10-100k

Torgue input is analog input for current limit setting. 0-5V signal to 0-25A current. ( if parameter 12 is =0 )  
If parameter value is something else than zero, then current limit is then = parameter value + analog input value.

Analog inputs above can also control with PWM signal. Recommended PWM frequency is over 400Hz.

Brake input is a digital input. Normally this activates brake function. It means that motor poles shorted and speed set to zero. But this input can be set to work also as start/stop input. Input functions can be set with parameter 11.  
In start/stop mode the start work with positive command.  
NOTICE ! Current limit doesn't limit braking current, so it is not recommend to use this for long and high inertia braking.

Direction input is a digital input. It will change the rotation direction. It uses automatically stop/start ramps during change.

Speed-2 input is a digital input which. enables speed-2, Speed presettet with parameter 13.

Stop/ disable input is a digital input, which disabled driver Motor goes to freewheeling ( all poles floating ). This input can be set to work also as reset with parameter 14 and 15  
This input has highest priority.

### INDICATIONS.

Fault led:  
Fast blinking = I-trip  
Random blinking = current limit  
Continuous = overtemp, disable input "on",

Fault output: ( Pin-16 PNP open collector output )  
Overtemperature, Overvoltage, Undervoltage.  
This indicates also I-Trip if parameter 16 is set to = 0

Overcurrent output : ( pin-19 PNP open collector out )  
This output indicates when current limit is exceeded.  
- if parameter 16 is set to =2 then it indicates also I-trip  
- if parameter 16 is set to =3 then it indicates only I-trip