

EM-241C-JS1 DC-MOTOR CONTROLLER 12-24V 15A

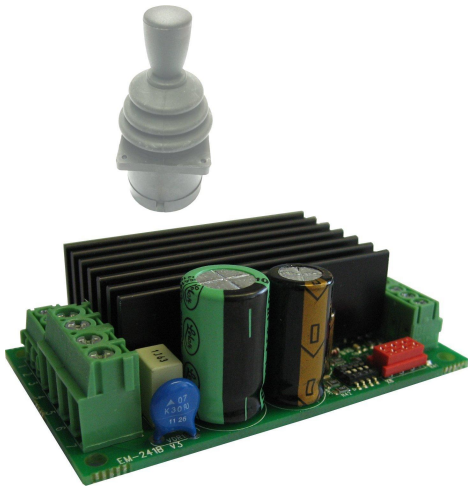

- JS1 is specially for joystick use
- three point calibration
- small size
- high current output
- current limit
- overvoltage brake
- 2 or 16kHz pwm frequency
- motors up to 200W
- own speed ranges for FW and REV.
- rail base mountable
- digital parameter setting
- JS1 program can be update also for standard EM-241 board

EM-241C-JS1 is a full bridge DC-motor starter. It is designed to joystick controlled DC-motor applications. Drive has adjustable acceleration and deceleration ramps, which make possible the smooth starts and stops. Adjustable current limit protects motor against overcurrent and it can also be used as an end-stop. This device has also two settable speeds, separate speed ranges for forward and reverse direction. Control input is specially designed for joystick control. The joystick range calibration is done automatically, when calibration function is activated. Calibration detects forward, reverse and midpoint positions. FAULT terminal has at the same time input and output function, the pin is normally high, but is pulled down in overheat and conditionally also in current trip situation. If FAULT-line is pulled down externally it will cause a stop and prevent the new start. For example, it is possible to link fault pins of several units together and achieve a synchronous stop. There is also special settings as start-kick which could be used if there is danger of stuck. Limit input can be individually set for NPN or PNP logic. The parameters settings can be done with various EM- interface units. Operation of the controller and some of its functional values can also be monitored with interface units.

TECHNICAL DATA (prog ver. 241C-JS1 v1.0)

Supply voltage cont. max. 10-35V
 Overvoltage limit adjustable 15-40V (connect motor to freewheel)
 Overvoltage dynamic brake 40V (shorting motor poles)
 Start up voltage 9V, shutdown voltage 8V
 Continuous current output when ambient temp. is < 50°C
 15A at 100% speed / 10A at 5-99% speed (pwm freq. 2kHz)
 10A at 100%speed / 5A at 5-99% speed (pwm freq 16kHz)
 Peak current (5s.) 30A at 2kHz / 25A at 16khz
 Current limit adjustable 0.1-25A (at start max. 30A)
 Overheat limit 100°C
 Start and stop ramp adjustable 0-5s
 PWM frequency 2kHz / 16kHz (selectable)
 Joystick input scale 0-5V or 0-10V (if dip 2 = ON)
 Input control logic: high =4-30V, low=0-1V
 Control input impedances typ. 47kohm
 Limit FW / BW input imped. typ 10kohm
 Control input response time typ 5ms.
 Fault out. NPN open coll. max 30V / 50mA
 Fault in activates Uin < 1V (NPN)
 Motor and supply connectors 2.5mm
 Control connectors 1mm
 Dimensions 42x72x25mm
 Dimensions in DIN-rail base 45x80x45mm
 CE-tested for industrial environment (emc)
 Operating temp (Ta) -40...60°C
 Weight 75g

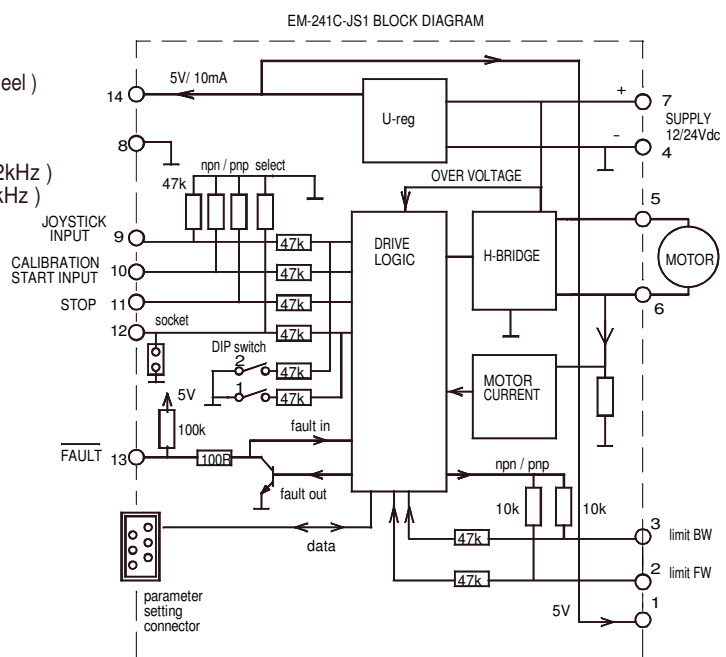

CONNECTIONS

Supply voltage must be filtered DC of 10-35V, and ripple should be less than 30% at full load.
CAUTION ! Wrong polarity can damage the unit.
CAUTION ! Unit doesn't have an internal fuse, so an external fuse should be added if fuse required.

MONITORABLE VALUES

- 1/6 Motor current 0-20A (0-200)
- 2/6 PWM-level-% 0-100% (0-100)
- 3/6 hour counter (max.65535h)
- 4/6 start counter (max.65535)
- 5/6 carry counter for start counter
- 6/6 joystick position 0-1024

FAULT-LED signal codes

- | | |
|---------------------|------------------------------|
| 1. power on | one blink |
| 2. current on limit | led is lit |
| 3. current trip | fast blinking... |
| 4. zero-cur trip | long blink- short pause... |
| 5. overvoltage | 4 x blink -pause... |
| 6. overheat | short blink- long pause... |
| 7. timeout | 3 x blink + long blink... |
| 8. fault input | 2 x short + 1x long blink... |

Special codes for calibration mode
 solid light = calibration can be done
 blink light = calibration is done

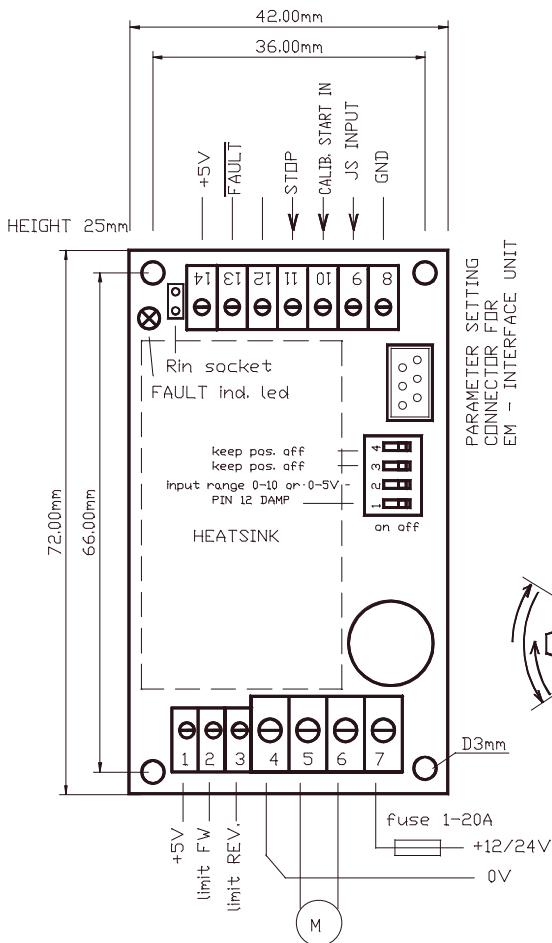

ADJUSTMENT AND SETTINGS (prog ver. EM-241C-JS1 v1.0)

Adjusting and parameter setting of eg. current limit value, ramp times and speed-2 value can be done with various EM-interface units EM-236 is basic parameter setting device. EM-268 and EM-328 are USB-serial converters, which makes possible to set parameters also with computer where is installed EmenTool Lite program. EM-326 is Bluetooth -dongle which can be used in smart devices with EmenTool App.

SETTABLE PARAMETERS 20pcs. (defaults in brackets)

- 1- not in use
- 2- not in use
- 3- input logic for limit inputs 1 or 2 PNP/NPN (1)
 1= limit inputs PNP 2= limit input NPN
- 4- max. speed FW. 0-100% / 0-100 (100)
- 5- max. speed REV. 0-100% / 0-100 (100)
- 6- current limit FW. 0.1-20A / 1-200 (30)
- 7- current limit REV. 0.1-20A / 1-200 (30)
- 8- current trip 0= disabled, 1= enabled : (1)
- 9- not in use
- 10- Fault output combinations: 0-2 (0)
 0= overtemp, current trip, overvoltage
 1= as above + calibration indication
 2= current limit indication
 NOTICE ! fault input is disabled in setting 2
- 11- overvoltage limit: 15-40V / 15-40 (35)
 Overvoltage can be caused by load driving the motor or when braking the speed down but supply can not accept the current back from driver. Exceeding the limit will cause the power stage set to free-wheel state. With a direct battery supply the brake current is charging the battery and the voltage will not normally rise. There is also 40V fixed dynamic brake point = motor pole shorted
- 12- load compensation: 0-255 / 0-255 (0)
 Load compensation (Rxl) improves low speed and start torque, but too high compensation achieve unstable running. Run motor at low speed (30%) Increase compensation with small steps until motor start behaviour unstable, then decrease value about 10%
- 13- timeout: 0-255s. / 0-255 (0=not in use) (0)
- 14- reset for start and hour-counter 0/1 (0)
 selecting 1 and push SAVE => reset counters
- 15- start ramp: 0-5s / 0-500 (50)
- 16- stop ramp: 0-5s / 0-500 (20)
- 17- start-kick 0-200ms / 0-200 (0)
 This gives full drive at start and I-lim is 30A
 The start kick length is 0-200ms.
- 18- Dead band wide 0-50% / 0-50 (5)
- 19- Freewheel options 0-3 (0)
 0= no freewheel
 1= freewheel when stopped
 2= freewheel during stop ramp.
 3= freewheel during stop ramp and if stopped
- 20- Pwm frequency 1=2kHz / 2=16kHz

JOYSTICK CALIBRATION

Give about 3s. control signal to CALIB input. when Fault-led of device will be lit:
 -push joystick full forward, then
 -pull joystick full reverse, then
 -release joystick to mid position, then
 -wait until led start to blink = calibration done

NOTICE ! calibration above defines joystick full fw, full rev. and mid point positions. But the max. speed can be set with parameters 4 and 5

