

## EM-337A-48V-SPF POSITIONING DRIVER for 4 PARALLEL DC-motor 24/48Vdc 4x8A / peak 4x15A , Rs-485

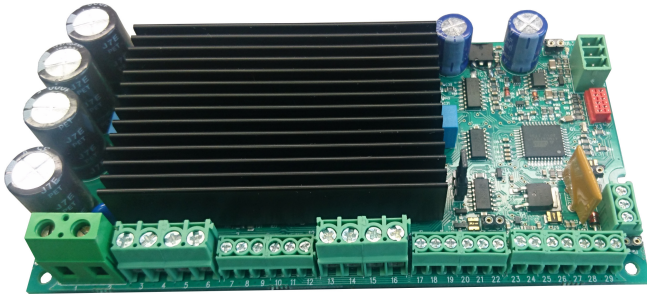

EM-337A-SPF

EM-337A-SPF is a parallel synchro controller for 4 DC-motors. The controller has four H-bridge power stages. The driver works with actuators that can offer pulse feedback signal. The control can be done with analog set signal and or alternatively with Rs-485 bus. This -SPF firmware version uses an analog SET signal, then driver works like servo driver and positioning actuators to the same value as the set value. The range of set value can be adjust with parameters.

The built-in synchronization control will keep all motors in the same speed and position. If synchronous error exceeds the set difference limit, all motors will be stopped. Device includes adjustable acceleration and deceleration ramps, which produce the smooth starts, stops and direction changes. Load compensation also enables good operation with asymmetric loads. Adjustable current limits can be set to protect motor and mechanics against overcurrent (over sized forces).

### TECHNICAL DATA

Supply voltage 20-58Vdc (nom. 24-48Vdc)  
 Undervoltage shutdown 8V  
 Overvoltage limit 58V  
 idle current < 20mA  
 Motor current: (@ 2kHz / 16kHz)  
 4x8A / 4x4A at continuous use  
 4x10A / 4x5A at duty cycle 25%  
 4x15A / 4x8A at duty cycle 10%  
 4x25A max. in start  
 Current limit, setting 1-25A  
 Overtemp limit 90°C  
 PWM frequency 2kHz or 16kHz  
 Input control logic levels:  
 "NPN" ON= 0-1V, OFF=4-30V or open  
 "PNP" ON=4-30V, OFF=0-1V or open  
 Control input impedances typ. 47 or 10kohm  
 Pulse input freq. max. 700Hz/ input ch  
 Pulse inputs pull- up/down 10 kohm.  
 Fault out. NPN open coll. max 30V/50mA  
 5V aux. output max 20mA  
 Position out 0-5V ( Rout 1kohm )  
 Position input 0-5V or 0-10V  
 Brake out NPN max. 4A  
 Rs-485 half-duplex 9.6 or 19.2 kbps  
 Supply connectors 4mm<sup>2</sup>  
 Motor/control connectors 2.5/1,5mm<sup>2</sup>  
 Weight 190g  
 Recom. oper. temp ( Ta ) -40...60°C  
 Over temp. shut down. 120°C ( pow.stage )  
 CE Electromagnetic compatibility  
 EN-55022B and EN 61000-6-2/ -4-2...6  
 Dimension and housing options:  
 - Card 142x73x28mm  
 - Installed in DIN-rail base 145x127x50mm  
 - Fibox PC150/60, (180x130x60mm)  
 - Fibox PC175/100 (180x180x100mm) include 300VA supply

### FEATURES

- positioning with 0-5V or 0-10V signal
- positioning also with Rs-485 Modbus
- synchronized 4 parallel driving
- operates with pulse feedback
- pulse counting PNP or NPN logic
- quadrature pulse counting
- current and temperature limit
- settable drive speed
- 2 or 16kHz pwm frequency
- acceleration and deceleration ramps
- stroke length limitation
- setting with serial interface
- brake ( release ) output
- safety switch input
- Rs-485 ( Modbus ) control
- safety reverse function
- The A version replaced earlier versions  
but A-version works only A-ver- firmware !

### APPLICATIONS

- table lifter
- hatch control
- worktop control

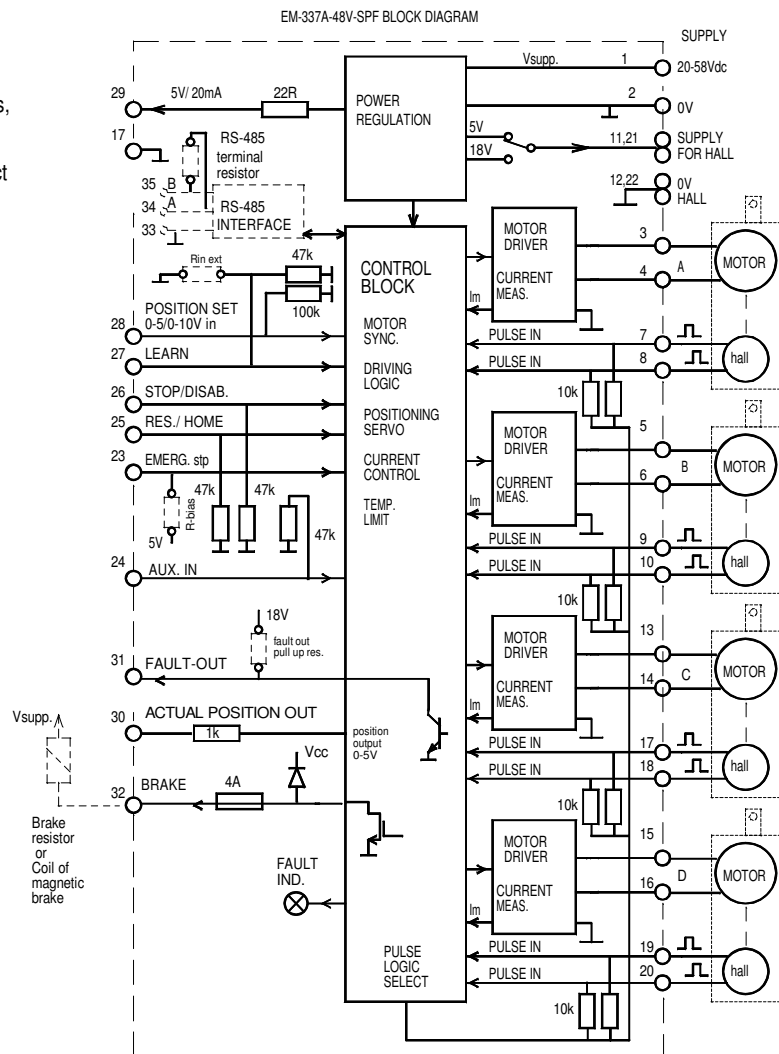

HEIGHT 25mm

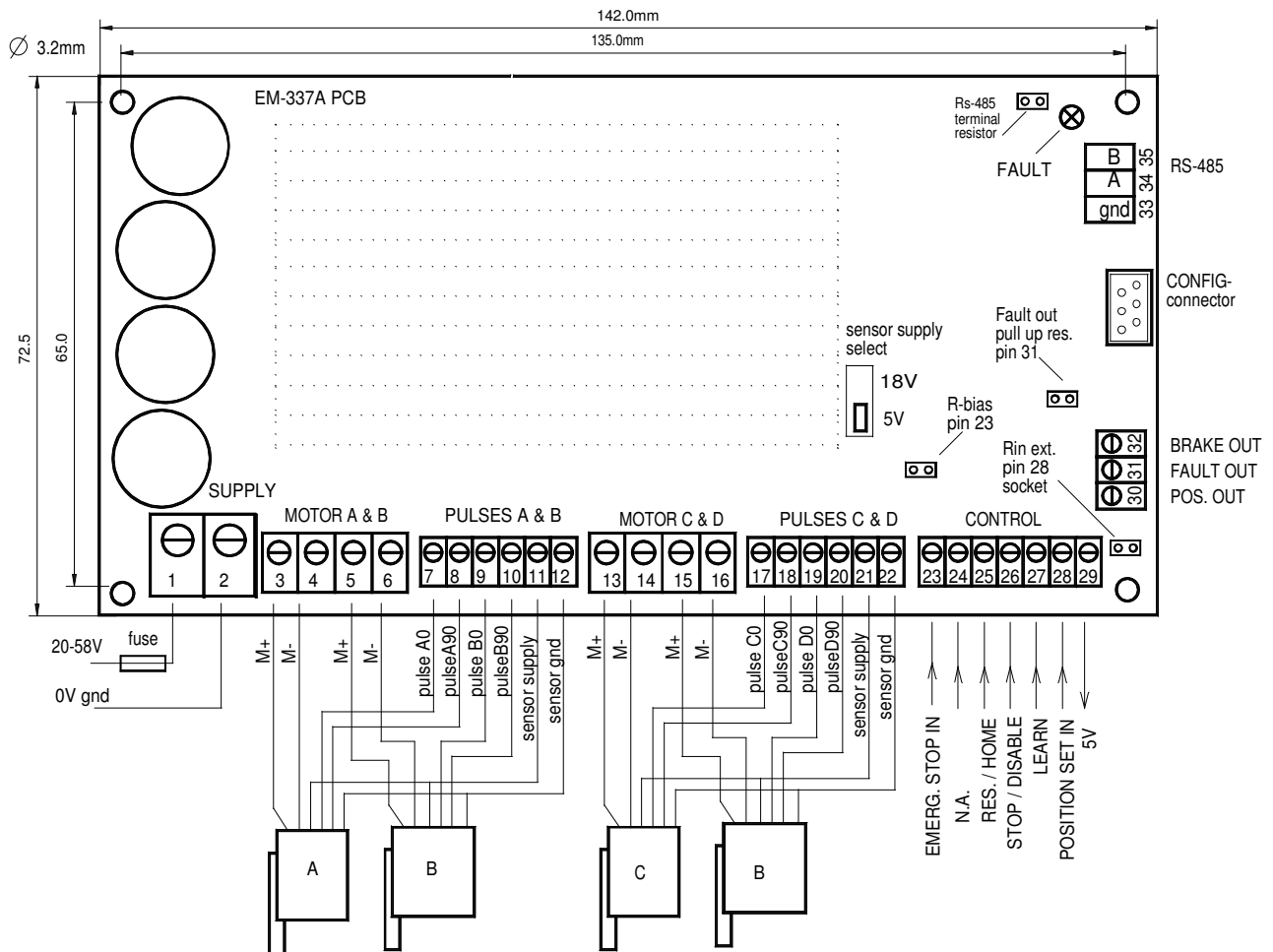

CONNECTION

In the drawing above, a typical connection of the card can be seen. Supply voltage should be 20-58Vdc filtered. Ripple less than 20%. Device has no inbuilt fuse, so use an external fuse, max. value 60A.

IMPORTANT.

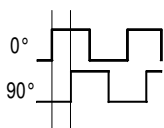

The phase shift of pulse lines should be about 90 deg. Also the frequency of one pulse sensor should be lower than 700Hz.

TERMINALS

PULSE SENSOR INPUTS can be set to work in NPN ( pull to gnd ) or PNP ( pull to positive ) mode. The modes are set with parameter 4. The hall switches of motors can be supplied with 18V or with 5V from card. Check the correct voltage from sensor or motor datasheet.

POSITION SET IN is an analog input for set value setting. This input range ( 0-5 or 0-10V ) can be set with parameter 5. If want to control with 0-20mA signal then can be set Rin socket the resistor 250ohm. ( 249ohm )

LEARN INPUT starts learning cycle. see page 4 for more info

STOP/DISABLE INPUT stops motors and keeps stopped as long as this occurred.

EMERGENCY STOP INPUT pin 23 is basically PNP input, but it can be work as wiring condition monitor input, in this mode it works as biased analog input. Monitor mode need in safety switch which has inbuilt resistor for wiring monitor.

This input can be set with parameter 7 and monitor bias resistor can be installed in R-bias socket. Wiring and R-bias value examples for safety switch on chapter EMERGENCY INPUT OPTIONS on page 5

RES. / HOME input is PNP input. Short command resets fault, long command ( >5s ) starts home routine. See page 4 for more info.

FAULT OUTPUT is normally an open NPN output, but if this output want to connect to PNP input. then have to install pull up resistor into "fault out res. socket". recommended value is 2.2kohm. Fault output function modes can be set with param 14.

BRAKE OUTPUT is NPN 4A output for releasing magnetic brakes of motors or alternatively for switching brake resistor in overvoltage situation. The function of this output can be set with parameter 8. The brake resistor or coil of magnetig brake can be connected from pin 32 to supply ( pin 1 )

POS. OUT is a actual 0-5V position output

Rs-485 This halfduplex serial port. Device can be Control and monitor with this bus. ( Modbus RTU ) Bus communication has own instructions.

## PARAMETER SETTING AND MONITORING

Parameter adjusting can be done with the following EM- interface devices.

- EM-236 is a basic stand alone setting device.
- EM-328 USB-serial converters, which makes it possible to set parameters with a computer that has EmenTool Lite installed.
- EM-326 is a Bluetooth-dongle, which can be used in smart devices with the EmenTool App.

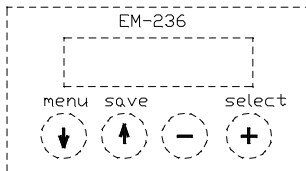

## MONITORABLE VALUES

- 1 fault code, as indication led blink count
- 2 motor A current - 0.1A/digit
- 3 motor B current - 0.1A/digit
- 4 motor C current - 0.1A/digit
- 5 motor D current - 0.1A/digit
- 6 current limit setting 0.1A/digit
- 7 motor A pulse counter value
- 8 motor B pulse counter value
- 9 motor C pulse counter value
- 10 motor D pulse counter value
- 11 normalised actual position 0-1023
- 12 normalised position set 0-1023
- 13 operating voltage 0.05V/digit
- 14 emerg. input level 0.05V/digit

## INDICATION LED ( number of blinks )

- Cont. light = homing/learning in progress
- 1 blink = homing/learning failed or position corrupted
  - 2 blinks = overcurrent
  - 3 blinks = no pulses detected
  - 4 blinks = motor position difference too big ( synchronisation error)
  - 5 blinks = overvoltage
  - 6 blinks = safety edge wiring failure
  - 7 blinks = Bus communication time-out

PARAMETER LIST EM-337A-spf v1.1  
(default in brackets)

- 1 Motor output max. voltage 10-50V / 0-50 ( 0 )  
0-9= max. is same as supply voltage  
10-50 = max voltage = parameter value
- 2 Overvoltage 15-60V / 15-60 ( 55 )  
don't set this higher than max supply 35Vdc
- 3 PWM frequency 1=2kHz , 2=16khz ( 1 )
- 4 Feedback ( Hall ) pulse logic 1=PNP , 2=NPN ( 2 )
- 5 Position set input max. range ( 1 )  
1= 0-5V  
2= 0-10V ( doubles param. 23 and 24 voltage values )
- 6 Not in use
- 7 Emergency stop input options ( pin 23 ) ( 2 )  
1= safety switch input with opening contact ( N.C. )  
2 =safety switch input with closing contact ( N.O. )  
3 =safety switch with ( N.O. ) and with line monitoring
- 8 Brake output activation ( pin 32 ) ( 0 )  
0= overvoltage ( exceeding param. 2 value )  
1 = "run" indication
- 9 Motor Speed 20-100% / 20-100 ( 100 )
- 10 Motor Speed-2 20-100%/ 20-100 ( 60 )
- 11 Current limit FW 0.1-25A / 1-250 ( 50 )
- 12 Current limit BW 0.1-25A / 1-250 ( 50 )
- 13 Start kick 0-250 ( 1 )  
0=start kick disabled  
1= start kick after homing ( 100ms )  
2 to 250 = start also after I-trip and the param. value defines start kick time as milliseconds
- 14 Fault output modes 1-4 ( 1 )  
1= output activates (= pull down ) if fault detected  
2= output shifting on/off, if homing or learning faults  
3= output shifting on/off in phase with indication led  
4= output activates when position is "positioned"
- 15 Start ramp 0-2.5s/ 0-25 ( 10 )
- 16 Stop ramp 0-1s / 0-10 ( 2 )
- 17 Pulse lost reaction time 0.01-1s / 1-100 ( 50 )
- 18 Safety reverse option 1-10s + direction / 0-30 ( 0 )  
0= disabled  
1-10 = reversing time 1-10s. both dir.  
11-20 = reversing time 1-10s. enabled only when run BW. dir  
21-30 = reversing time 1-10s. enabled only when run FW dir.
- 19 Load compensation 0-255 / 0-255 ( 0 )
- 20 Synchronisation strength 1-50 / 1-50 ( 10 )
- 21 Braking area 1-8% / 1-8 ( 4 )
- 22 Dead zone 0.1-5% / 1-50 ( 10 )
- 23 Set input min 0-5.50V / 0-551 ( 0 )
- 24 Set input max. 0-5.50V / 0-551 ( 550 )  
aboves parameter 551 is a auto setting mode
- 25 Range limit BW direction 0-50% / 0-500 ( 5 )
- 26 Range limit FW direction 0-50% / 0-500 ( 5 )
- 27 Full range 0-65000 pulses / 0-65000 ( 1000 )
- 28 Serial line configuration, speed, parity, and number of stop bits ( 1 )  
1 =9600bps 8N1 5 =19200bps 8N1  
2 =9600bps 8N2 6 =19200bps 8N2  
3 =9600bps 8E1 7 =19200bps 8E1  
4 =9600bps 8O1 8 =19200bps 8O1
- 29 Modbus address 1-247 ( 1 )

## CONNECTION

Connect motors and supply as in picture (page2). Supply voltage 28-58Vdc must be filtered. Ripple less than 20%. Device has no inbuilt fuse, so use external fuse, recommended value range 10-60A.

## START-UP

First when the device is turned on a parameter check should be made. Connect interface unit in to device and change parameters to suit the application, most important is to check: pulse logic, current limit and full range.

## HOMING CYCLE ( position counter reset )

At the start of use the pulse counters of device has to reset, and in some situation device might lose the position information, for example when it moved manually while the power is off. In above cases the position counter can be matched with homing routine. In the homing the motors run at speed-2.

## START THE HOMING CYCLE

The homing routine is activated with 5 second command for RES/HOME input. After starting motors run BW direction and ind. led turn on. NOTICE !Keep command "on" until motor stops and led turn off . If one of the motor does not reached the end or led stay blinking, then start homing routine again so many time that all are reached the and indication led is turned off

## LEARNING CYCLE ( position counter range set )

The learning cycle idea is learn the right range for device with special running cycle. After completing the learning cycle successfully, the device has automatically set a mechanical operating range for itself. The range can be compressed manually with parameter 25 and 26

NOTICE! learning is not necessary if already known the full range pulse count. then can be set manually full range parameter

## START THE LEARNING CYCLE

Learn routine starts with positive command for learn input ( pin 27 ) Motors start to run and led turn on. NOTICE ! - Keep command "on", until led turns off. If led stay blinking then try again drawing below shows how the learning should progress. NOTICE 2 - remove interface unit ( EM-236A or EM-328 ) during this learning process

Full Range = mechanical range end to end

HOME makes steps 1 to 3  
LEARNING steps 1 to 6

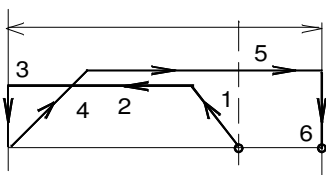

1. Start to BW direction (led turn on)
2. Run to BW direction speed-2
3. BW end ( led turn off in homing )
4. Start to run FW direction
5. Run and count to FW direction with speed-2
6. Reach FW end, device set full range (led turn off)

## TROUBLE SHOOTING AT HOMING AND LEARNING ROUTINE

- A: motor run only about second and indication led blinking  
- check parameter 4  
- check pulse sensor voltage  
- pulse sensor phasing is wrong = wrong counting direction  
-> swap the pulse wires or motor wires
- B: motor run not at all:  
-current limit is too low, check parameters 11 and 12  
-motor or system is mechanically stuck
- C: The homing works, but into the wrong direction, then swap the motor wires and also swap the pulse sensor wires.

## SET RANGE ( input range of position set signal)

The analog position set input is pin 28, This input range can be set with parameters 5, 23 and 24. The basic range is selected with param. 5 options are 0-5V or 0-10V. Parameter 23 and 24 is for fine tuning of range.

Example 1 control signal is 0.1-3V, then set param. 23 = 10 and param. 24 = 300.

Example 2: Control signal is 4...20mA, then plug in Rin-ext resistor 250ohm, this convert mA signal to voltage signal 1-5V, then set param. 23 = 100 and param. 24 = 500.

Example 3: Control signal is 0-10V, set param. 5=2 and 23=0 and 24 = 500. Notice the parameter 5 selection has doubled the voltage values of param.

## Example 4: Auto set

Adjust the control signal to the min. value, set param. 23 to value 551 and SAVE, card will set automatically adjusted value to the parameter value. Same time Adjust max. value to the input and set param. 24 to the value 551 and SAVE. Now the min. and max. should be set to suitable for this application. NOTICE. after this procedure you have to remove interface unit and then connect it again, and read parameters (load & edit) and save parameters (save).

## RANGE LIMITATION

The learned range can be limited with param 25 and 26

1. Original learned range = mechanical full range = position counter normalized to 0 - 1023 in learning
2. Modified range example:  
BW limit = 20,0% and FW limit = 30,0%.  
Now the stroke of actuator is compressed so that position set min. to max. = 20% to 70% mech. range

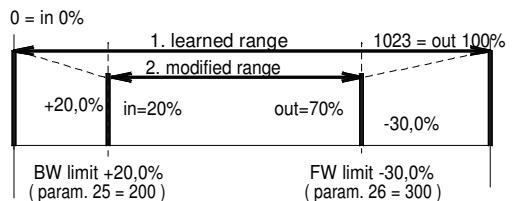

## FULL RANGE.

Full range parameter 27 can be set also with manually instead of learning routine. If you already known the full range of application, then you don't need to make learning. You can also manipulate the mechanical full range of system with adjusting full range parameter. Increasing of the value will expand the mechanical range and vice versa.

## POSITIONING COMPARATOR ( positioning behaviour )

Positioning accuracy and dynamic ( param. 21 and 22 ) Brake area is a slowing down slope when approaching the set point, faster application will need wider braking area. The dead zone is area where motor is "positioned" Narrow dead zone means better accuracy, but too narrow dead zone could generate vibration.

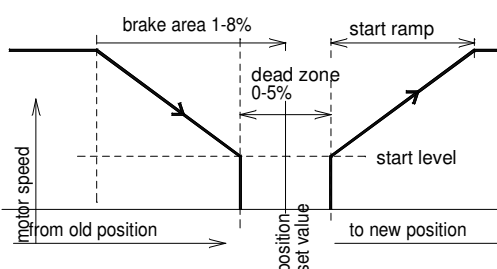

## START AND STOP RAMPS

ramps smooths start and speed changing. These are set with parameter 15 and 16

## CURRENT LIMIT ( torque limit )

All motor has own current limit measuring, if current of one of motor exceeds the current limit, then all motors will shut down. Overcurrent shut down is disabled during start ramp, but the current limitation is always active and it protects against overtorque. Current can be set separately for FW and BW direction with parameter 11 and 12.

## PWM FREQUENCY

Driver has two option for pwm frequency 2 or 16kHz, with 2kHz power stage has lower losses and it can give more output current. But 2kHz can also generate whistling voice, this can be avoided with selecting 16kHz frequency.

## SPEED ( without speed regulation = parameter 1=0 )

Driver has two speed setting parameter 9 and 10. These param. determines the output voltage of the motors in relation to the supply voltage. for example 50% at 48Vdc supply voltage means 24V motor voltage. The speed-1 is normally in use. The speed-2 is enabled in homing and learning cycle.

## MOTOR OUTPUT MAX. VOLTAGE ( speed regulating )

This function regulates motor speed so that changes of supply voltage will not affect the motor speed. This is enabled and adjusted with parameter 1. For example, if supply voltage varies 48-56V, then you can set this parameter to value 48V. which means that motor output 100% =48V. If this function is disabled ( param. 1=0 ) then 100% output is = supply voltage

## LOAD COMPENSATION ( torque at low speed )

If the motor seems to be lag of torque at high load, specially at small position changing its endurance can be improved with compensation parameter 19. Increase slowly the parameter's value for example by 10 units and make loading test, repeat this until you get torque enough for low speed. However, setting a too high value will make the motor twitch.

## SYNCHRO STRENGTH

The parameter 20. defines how strong the synchronisation is between the motors. The bigger value means stronger synchronisation, which means that motors follow stronger to each other, but too big value could generate twitching.

## DIFFERENCE LIMIT ( unsynchronous. shutdown )

If difference between motor increases more than 50 counts, then difference limit detection will shutdown motors. Recovery from this situation only with home or learning.

## SAFETY "REVERSE" FUNCTION

This function reversing motors automatically if system meets obstacle. With parameter 18 can be set the direction when function is enabled and also how long time motor reversing. This function trigs on from current limit, pulse lost or with command from emergency stop input. Notice! that emergency stop input start safety reverse only BW direction

## PULSE LOST REACTION TIME

Parameter 17 defines delay time for pulse lost shutdown. If some of motors don't give pulses then all motors stopped Default value for reaction time is 0.5s

## EMERGENCY INPUT OPTIONS

This input is especially for external safety switch Safety switch has usually monitoring resistor, which has used to monitoring the condition of safety switch wires. This input has possibility to monitoring this line when "safety switch" option has selected with parameter 7. R-bias has own socket on board. R-bias is selected suitable with safety switch resistor. below few examples.

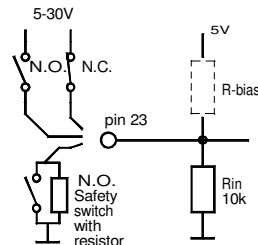

Examples for bias resistor  
switch res. 1k then R-bias 1k  
switch res. 2.2k then R-bias 1.8k  
switch res. 4.7k then R-bias 3.3k  
switch res. 10k then R-bias 4.7k

## FAULT RESETING

Current limit and pulse lost errors will be reset with "new" opposite direction command or also with reset command to pin 25.

Homing failure and difference limit errors have to reset with new "homing" routine

Overtemp and overvoltage error will be reset automatically, when error situation disappear

## OVERVOLTAGE ( brake output in overvoltage situation)

Brake output can be used to control so called brake resistor which work like shunt regulator and absorb the overvoltage The resistor to be connected from supply to pin 32 In this use the param. 8 must be = 0 and the param. 2 defined the activation point of brake output.

If supply voltage exceed the set value of param. 2 then this output is activated ( brake resistor activate ) If supply voltage despite of this still increases then the motor output of the driver will set to freewheel.

NOTICE! don't set param. 2 higher than recom. supply voltage max.

## START KICK

This routine which can be given after homing or I-trip. It means motor starts short time with full power to release possible mechanical jamming. This is configured by parameter 13