

EM-282D-JS1 DC-MOTOR CONTROLLER 12-48V 100A

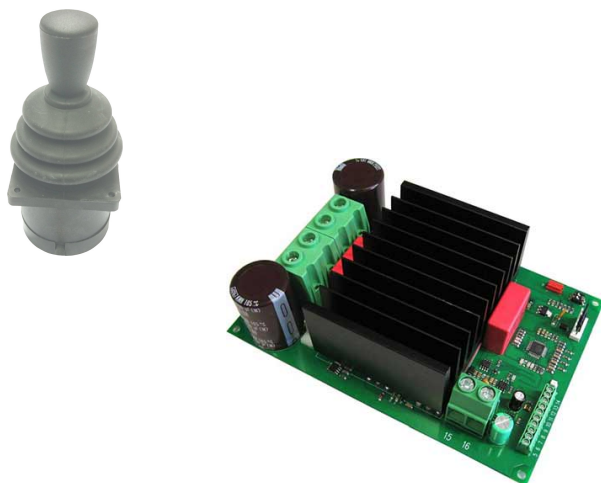

- JS1 is specially for joystick use
- three point calibration
- small size
- high current output
- current limit
- for motors up to 1.5kW
- overvoltage brake
- own speed ranges for FW and REV.
- rail base mountable
- digital parameter setting
- JS1 program can be update also for standard EM-282 board
- Prog. 1.3 direction change input added
- Prog. 1.4 stop input, brake output and fan output options added
- Prog 1.6 wire breakage detection added
- prog v1.7 (for D-board only) Rs-485 added
- D-board series has extended supply range

EM-282D-JS1 is a full bridge DC-motor starter. It is designed for joystick controlled DC-motor applications. The driver has adjustable acceleration and deceleration ramps, which enable the smooth starts and stops. Adjustable current limit protects the motor against overcurrent and it can also be used as an end-stop. This device has also two settable speeds, separate speed ranges for forward and reverse direction. Control input is specially designed for joystick control. The joystick range calibration is done automatically, when calibration function is activated. Calibration detects forward, reverse and midpoint positions. FAULT terminal has simultaneously both input and output functions, the pin is normally high, but is pulled down in overheat and conditionally also in current trip situation. If FAULT-line is pulled down externally it will cause a stop and prevent it from starting again. For example, it is possible to link fault pins of several units together and achieve a synchronous stop.

There are also special settings as start-kick which can be used in case the device is in danger of being jammed.

Limit input can be individually set for NPN or PNP logic.

This D-version has added Rs-485 serial port for Modbus communication possibility.

The parameter's settings can be done with various EM- interface units. Operation of the controller and some of its functional values can also be monitored with interface units.

TECHNICAL DATA (EM-282 pcb -D ver.1 prog JS1 v1.7)

Supply voltage nom. 12-48Vdc (abs. limits 10-60V)
 Shutdown voltage 10V
 Overvoltage limit adjustable 15-60V
 Idle current typ 20mA
 Motor current max. cont. 100A (at 24Vdc and 25°C amb. temp)
 80A and 100A with fan installed (at 24Vdc and 60° amb. temp)
 -Motor currents are about 20% lower with 16kHz pwm freq.
 -At 48V supply voltage motor current is typically 15% less
 Braking load current (pin 16) max cont 50A peak 100A
 Current limit adjustable 1-200A
 NOTICE! current limit is 20% boosted during start ramp.
 Over temp. limit 100°C
 Start and stop ramp adjustable 0-5s
 PWM frequency 2kHz / 16kHz
 joystick input scale 0-5 or 0-10V (if dip 1 is ON)
 Input control logic: high =4-30V, low=0-1V
 Control input impedances typ. 10kohm
 Control input response time typ 5ms.
 Fault out. NPN open coll. max 42V / 0.5A
 Fault in. actives $U_{in} < 1V$ (NPN with 100k pull up)
 Rs-485 bus, halfduplex, ModbusRTU, 9.6/19.2 kbps
 Motor and supply connectors 16mm²
 Control connectors 1mm²
 Dimensions 180x122x60mm
 CE-tested for industrial environment (EMC)
 Operating ambient temp (T_a) -40...60°C
 Weight 750g

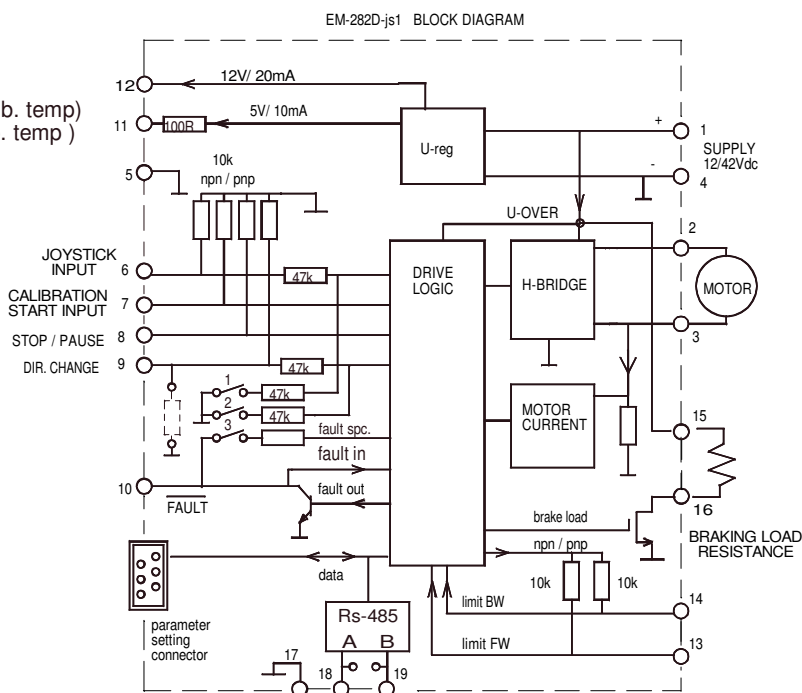

CONNECTIONS

Supply voltage recommendation is 12-48VDC and ripple should be less than 30% at full load. Supply voltage limit is 60Vdc
CAUTION ! Wrong polarity can damage the unit.
CAUTION ! Unit doesn't have an internal fuse, so an external fuse should be added if fuse required.

MONITORABLE VALUES

1/6 Motor current 0-20A (0-200)
 2/6 PWM-level-% 0-100% (0-100)
 3/6 hour counter (max.65535h)
 4/6 start counter (max.65535)
 5/6 carry counter for start counter
 6/6 joystick position 0-1024

FAULT-LED signal codes

1. power on	one blink
2. current on limit	led is lit
3. current trip	fast blinking...
4. zero-cur trip	long blink- short pause...
5. overvoltage	4 x blink -pause...
6. overheat	short blink- long pause...
7. timeout	3 x blink + long blink...
8. fault input	2 x short + 1x long blink...

Special codes for calibration mode
 solid light = calibration can be done
 blink light = calibration is done

ADJUST AND SETTINGS (prog ver. EM-282D-JS1 v1.7)

Adjusting and parameter setting of eg. current limit value, ramp times and speed-2 value can be done with various EM-interface units EM-236 is basic parameter setting device. EM-268 and EM- 328 are USB-serial converters, which makes it possible to set parameters also with computer where is installed EmenTool Lite program.

DIP SWITCHES

Dip-1 Damping pin 6 if set ON (joystick input)
 Dip-2 Damping pin 9 if set ON

SETTABLE PARAMETERS 21pcs. (prog. EM-282D-js1 v1.7) (defaults in brackets)

- 1- not in use
- 2- stop input options 0-1 (input pin 8) (0)
 0= stop with command , new start is possible
 1= stop command stops with ramp and stay stopped as long as command occurred, it starts again when when command disappears
- 3- input logic for limit inputs 1-4 PNP/NPN (1)
 1= limit inputs PNP 2= limit input NPN
 3= limit inputs PNP N.C. 4=limit inputs NPN N.C.
 (N.C. = normally closed = open circuit stops)
- 4- max. speed FW. 0-100% / 0-100 (100)
- 5- max. speed REV. 0-100% / 0-100 (100)
- 6- current limit FW. 1-200A / 1-200 (30)
- 7- current limit REV. 1-200A / 1-200 (30)
- 8- current trip 0= disabled, 1= enabled : (1)
- 9- Brake output pin 16 options 0-1 (0)
 0 =overvoltage, 1= "run" indication
- 10- Fault output pin 10 combinations: 0-3 (0)
 0= overtemp, current trip. overvoltage
 1= as above + calibration indication
 2= current limit indication
 3= "run" indication
NOTICE ! fault input is disabled in settings 2 and 3
- 11- overvoltage limit: 15-60V / 15-60 (55)
 Overvoltage can be caused by load driving the motor or when braking the speed down but supply can not accept the current back from driver. Exceeding the limit will cause the power stage set to free-wheel state.
 With a direct battery supply the brake current is charging the battery and the voltage will not normally rise.
 There is also 60V fixed dynamic brake point = motor pole shorted
- 12- load compensation: 0-255 / 0-255 (0)
 Load compensation (Rxl) improves low speed and start torque, but too high compensation achieve unstable running.
 Run motor at low speed (30%) Increase compensation with small steps until motor start behaviour becomes unstable, then decrease value about 10%
- 13- timeout: 0-255s. / 0-255 (0=not in use) (0)
- 14- reset for start and hour-counter 0/1 (0)
 selecting 1 and push SAVE => reset counters
- 15- start ramp: 0-5s / 0-500 (50)
- 16- stop ramp: 0-5s / 0-500 (20)
- 17- start-kick 0-200ms / 0-200 (0)
 This gives full drive at start and I-lim is 30A
 The start kick length is 0-200ms.
- 18- Dead band 0-50% / 0-50 (5)
- 19- Freewheel options 0-3 (0)
 0= no freewheel
 1= freewheel when stopped
 2= freewheel during stop ramp.
 3= freewheel during stop ramp and if stopped
- 20- Pwm frequency 1=2kHz / 2=16kHz (2)
- 21- Braking current limit 5-200A / 5-200 (50)

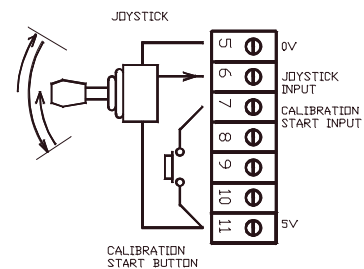
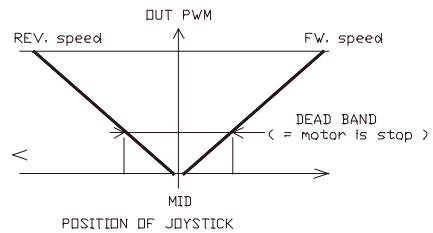
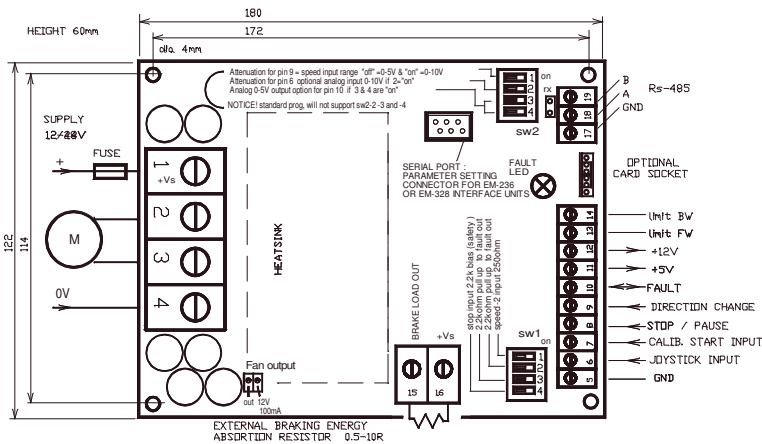

NOTICE ! calibration above defines joystick full fw, full rev. and mid point positions. But the max. speed can be set with parameters 4 and 5

NOTICE 2 ! Firmware version 1.6 and later has added joystick wire breakage detection This function watches pin 6 voltage, and if it goes to 0V or open circuit, then driver will shutdown motor. (fault ind. with 2 blink + pause)

JOYSTICK CALIBRATION

Give about 3s. control signal to CALIB input. when Fault-led of device will be lit:
 -push joystick full forward, then
 -pull joystick full reverse, then
 -release joystick to mid position, then
 -wait until led starts to blink = calibration done